

# Clarke®

## X-PRO



## SABRE SAW

MODEL NO: CAT167

PART NO: 3120181

## OPERATING & MAINTENANCE INSTRUCTIONS

UK  
CA | CE

ORIGINAL INSTRUCTIONS

GC0522

---

## INTRODUCTION

---

Thank you for purchasing this CLARKE Sabre Saw, suitable for cutting metal, wood, polymers and other materials.

Before attempting to use this product, please read this manual thoroughly and follow the instructions carefully. In doing so you will ensure the safety of yourself and that of others around you, and you can look forward to your purchase giving you long and satisfactory service.



**Please keep these instructions for future reference.**

---

## SAFETY SYMBOLS

---

Please read all of the safety and operating instructions carefully before using this product. The following safety symbols are to be found on the machine.

	Read this instruction booklet carefully before use.		Wear ear protection
	Wear eye protection		

---

## GUARANTEE

---

This product is guaranteed against faulty manufacture for a period of 12 months from the date of purchase. Please keep your receipt which will be required as proof of purchase.

This guarantee is invalid if the product is found to have been abused or tampered with in any way, or not used for the purpose for which it was intended.

Faulty goods should be returned to their place of purchase, no product can be returned to us without prior permission.

This guarantee does not effect your statutory rights.

---

## GENERAL SAFETY RULES

---



CAUTION: FAILURE TO FOLLOW THESE PRECAUTIONS COULD RESULT IN PERSONAL INJURY, AND/OR DAMAGE TO PROPERTY.

---

### WORK ENVIRONMENT

1. Keep the work area clean and tidy.
2. Dress appropriately: - do not wear loose clothing or jewellery. Tie long hair out of the way.
3. Keep children and visitors away - do not let children handle the drill.
4. Do not operate the saw where there are flammable liquids or gases.
5. Stay alert and use common sense - do not operate the saw when you are tired or under the influence of alcohol, drugs or medication.
6. Always wear eye protectors when using the saw - Eye protection must provide protection from flying particles from the front and the side.
7. Always wear ear protectors and face mask when using the saw.
8. Do not overreach - Keep proper footing and balance at all times.

### USE OF AIR POWERED TOOLS

1. Never use any type of bottled gas as a source of power for an air tool.
2. Do not connect the air supply hose with your finger on the trigger.
3. Do not exceed the maximum pressure for the saw 90 psi / 6.2 bar.
4. Check hoses for leaks or worn condition before use and ensure that all connections are secure.
5. Keep the air supply hose away from heat, oil and sharp edges.
6. Do not use this saw for any other purpose than that described in this manual.
7. Do not fit this saw to any stand or clamping device that may damage it.
8. Do not carry out any alterations or modifications to this saw.
9. Always disconnect from the air supply when:
  - Performing any maintenance
  - The saw is not in use.
  - The saw will be left unattended.

- Moving to another work area.
  - Passing the saw to another person.
10. Never use the saw if it is defective or operating abnormally.
  11. Always ensure the saw has stopped before putting it down.
  12. The saw should be repaired if required by qualified service personnel.
  13. Avoid damaging the saw for example by applying excessive force.
  14. ALWAYS maintain the saw with care. Keep it clean for the best and safest performance.
  15. Quick change couplings should not be located at the air tool. They add weight and could fail due to vibration.
  16. Do not force or misuse the saw. It will do a better and safer job at the rate for which it was designed.
  17. Do not remove any labels. Damaged labels should be replaced.
  18. This saw vibrates with use. Vibration may be harmful to your hands or arms. Stop using the saw if discomfort, a tingling feeling or pain occurs. Seek medical advice before resuming use.
  19. Never carry the saw by the air hose.
  20. Never carry the saw with your finger on the trigger.

# PRODUCT DESCRIPTION

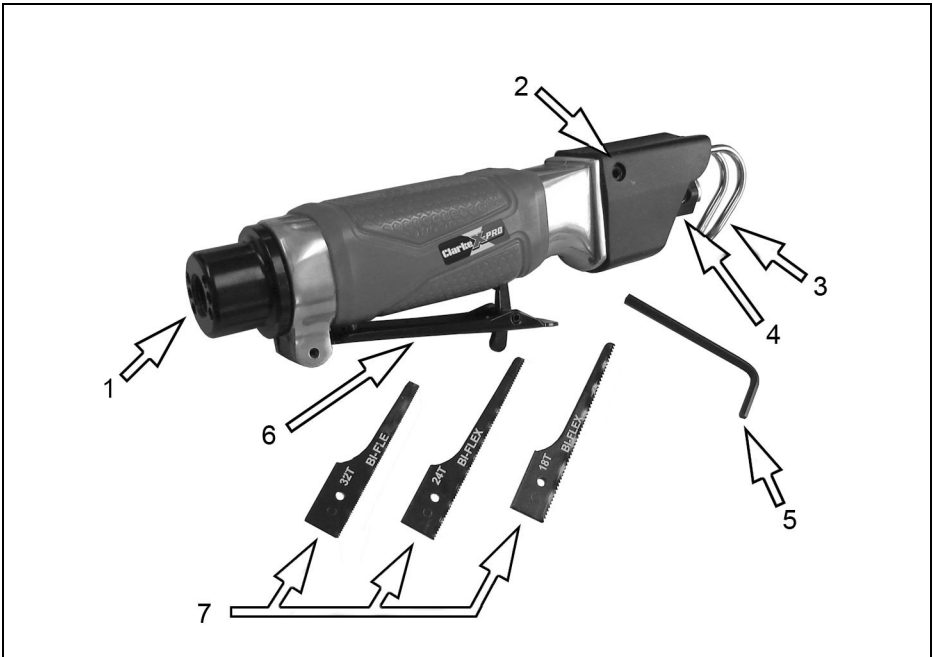

NO	DESCRIPTION
1	Air Inlet
2	Adjusting Setscrew
3	Work Guide
4	Blade Holder

NO	DESCRIPTION
5	Allen Key
6	Safety Trigger
7	3 x Saw Blades (18,24,32 tpi)

The CAT167 sabre saw is a compact and ergonomic tool with rubber protective grip. It features adjustable work guide to set cut depths. The blade holder design makes the saw blade installation and replacement fast and easy. The intended use includes cutting mild steel sheet at auto body shops, garages and other workshops. It also suitable for cutting reinforced fiberglass, aluminum, wood, etc.

# COMPRESSED AIR REQUIREMENTS



**WARNING: COMPRESSED AIR CAN BE DANGEROUS. ENSURE THAT YOU ARE FAMILIAR WITH ALL PRECAUTIONS RELATING TO THE USE OF COMPRESSORS AND A COMPRESSED AIR SUPPLY.**

- Use only clean, dry, regulated compressed air as a power source.
- Air compressors used with the tool must comply with the appropriate European Community Safety Directives.
- A build-up of moisture or oil in the air compressor will accelerate wear and corrosion in the tool. Ensure any moisture is drained from the compressor daily and the inlet filter is kept clean.
- If an unusually long air hose is required, (over 8 metres), the line pressure or the hose inside diameter may need to be increased.
- The air hose must be rated at least 150% of the maximum operating pressure of the tool.

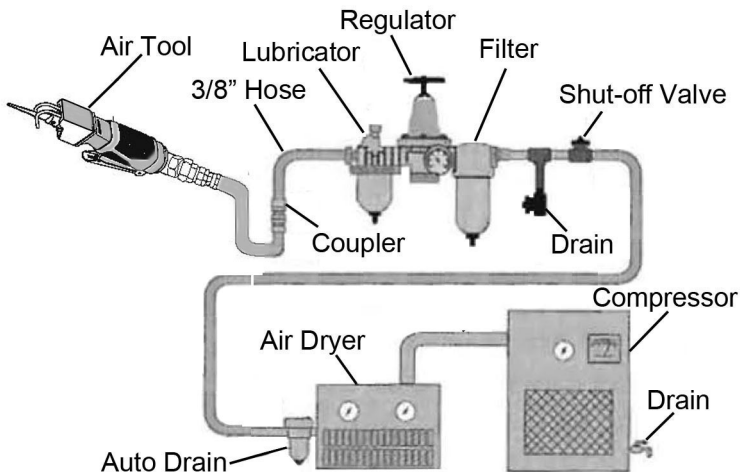

- A typical air line layout is shown above. If an automatic in-line filter/regulator is used, it will keep the air tool in good condition, but should be regularly checked and topped up with oil. SAE 10 oil should be used and the lubricator adjusted to approx 2 drops per minute.
- The minimum hose diameter should be 5/16" (8mm) ID and fittings should have the same internal dimensions.

- Never exceed the maximum operating pressure for the air tool. It is recommended that air pressure to this tool does not exceed 90 psi (6.2 bar) at the tool when running. Higher pressures and unclean air will shorten the life of the tool due to faster wear and is a possible safety hazard.

---

## BEFORE USE

---



**WARNING: MAKE SURE THAT THE SAW IS DISCONNECTED FROM THE AIR SUPPLY BEFORE INSTALLING, REMOVING OR REPLACING THE BLADE.**

---

### FITTING/REPLACING THE BLADE

1. Loosen the set screw (A) on the blade holder (B) with the hex key (C) provided, by turning counterclockwise.
2. Identify the material and then select the correct blade for your operation.
3. Always use the correct saw blade for the material for smooth and fast cutting.

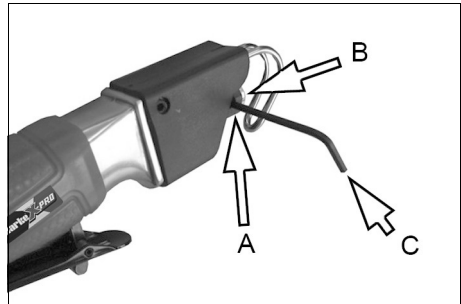

- It is recommended that operators use 32T blades for cutting light sheet metal, body panels, exhaust pipes, etc., use 24T blades for general purpose sawing including aluminum and other soft materials, and use 18T blades for cutting plastic, reinforced fiberglass, wood, etc.

4. Insert a saw blade (D) into the blade holder as far as it will go.

5. Tighten the set screw (A) with the hex key by turning clockwise. Ensure the saw blade is held tightly to avoid it coming loose.

6. Loosen the setscrew (E) and adjust the position of the work guide (F) according to the depth of cut required.

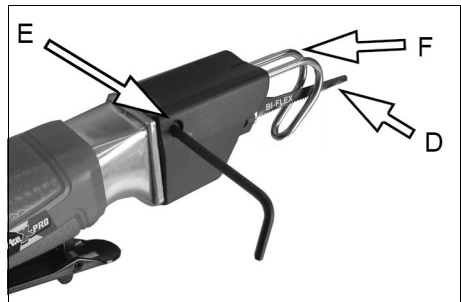

## CONNECTING THE AIR LINE

1. Remove the protective plug from the air inlet and connect a suitable hose as shown.
2. A gauze filter is fitted within the air inlet. Ensure this is always in place and is kept clean. The air line is connected to the adapter, preferably via a quick release coupling (not supplied).
3. Connect the other end of the hose to the compressed air supply.
4. Ensure the trigger is NOT depressed when connecting the air line.
5. Turn on the air supply and check for air leaks. Rectify any found before proceeding.
  - PTFE tape may be useful for sealing threaded connections.
6. If required, connect an in-line mini oiler to the airline close to the air tool.
  - A mini oiler helps to prolong the life of any air tool.
7. If a mini-oiler is not being used, run a few drops of oil through the air tool before use. It can be entered through the airline inlet or via the hose at the nearest connection to the air supply.
  - Your sabre saw is now ready for use
  - You can fit a whip hose with a quick fit coupling if required (available from your Clarke dealer.)

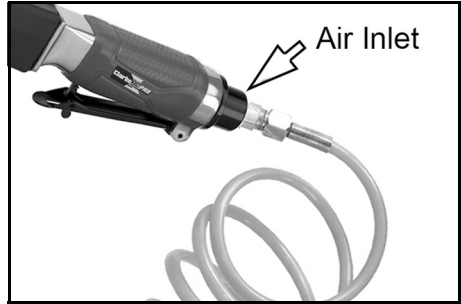

## USEFUL AIRLINE ITEMS FROM THE CLARKE RANGE

CAT150 Mini-Oiler:- Part No 3120164

8mm Rubber Whip Hose:-Part No 3120104

CAT58 6mm Recoil Hose with 1/4" bsp connectors (25 feet):-Part No 3110458

CAT59 6mm Recoil Hose with 1/4" bsp connectors (50 feet):-Part No 3110459

CRH9 9metres professional recoil hose:-Part No 3120100

CAR20PC Manual Air Hose Reel:-Part No 3126250

CAR15PC PVC hose in moulded case with auto re-wind:-Part No 3126000

See the latest catalogue for details of snap couplings & pressure gauges



---

## OPERATION

---

### OPERATING THE SAW

1. Adjust the work guide as required as shown on page 7.
2. Slide the safety lock forward and squeeze the trigger. Allow the saw to reach full speed before use.
3. Release the trigger to stop the saw. When the blade has stopped remove it from the workpiece.



### DISCONNECTING THE AIR SUPPLY

1. Do not disconnect the air supply hose until the air supply has been shut down and the compressed air released from the hose.
  - Refer to the compressor instruction manual for the procedure to shut down and release the compressed air.
  - Once the pressure has been released, disconnect the air supply hose from the saw.

---

## MAINTENANCE

---



**WARNING: MAKE SURE THAT THE SAW IS DISCONNECTED FROM THE AIR SUPPLY BEFORE STARTING ANY CLEANING OR MAINTENANCE PROCEDURES.**

Please note that factors other than the tools condition may effect its operation and efficiency, such as reduced compressor output, excessive drain on the airline, moisture or restrictions in the air-line, or the use of connector

### DAILY

1. Before use, drain water from the air-line and compressor.
2. Lubricate the saw daily for optimum performance. Use a high quality airline oil either via a lubricator in the air supply system or by placing a few drops into the air inlet immediately before use. This should be carried out regardless of whether or not an in-line lubricator is used.

## **CLEANING & OVERHAUL**

1. Keep the saw clean and free from debris.
2. If the saw becomes sluggish and the air supply is of good quality, it may be necessary to replace worn or damaged parts.
3. Grit or gum deposits in the mechanism may eventually reduce efficiency. This condition can be corrected by cleaning the air inlet filter and flushing out the saw with gum solvent oil or an equal mixture of SAE No10 oil and paraffin.
4. Failing this, the saw should be disassembled, thoroughly cleaned, dried and reassembled. You may prefer to take the saw to your CLARKE dealer if internal maintenance is required.

## **STORAGE**

If the saw is to be stored or is idle for longer than 24 hours, run a few drops of Clarke air-line oil into the air inlet and depress the trigger in order to lubricate the internal parts.

When not in use, the saw should be disconnected from the air supply and stored in a dry place out of the reach of children. Avoid storing in a damp environment.

## **ACCESSORIES**

A wide range of accessories is available including filter/regulators, lubricators, high-pressure hoses (5 to 50 metres) etc.

Contact your CLARKE dealer for further information or CLARKE International Service Department on 01992 565333.

Clarke Air Line Oil (part no. 3050825) is available from your CLARKE dealer

Replacement blades are available as follows:

3-Pack 18tpi - Part no: 3120184

3-Pack 24tpi - Part no: 3120185

3-Pack 32tpi - Part no: 3120186

# TROUBLESHOOTING

SYMPTOM	PROBLEM	SOLUTION
Tool runs at normal speed but slows down under any load.	<ol style="list-style-type: none"> <li>1. Excessive pressure on drill.</li> <li>2. Motor parts worn.</li> <li>3. Worn or sticking mechanism due to lack of lubricant.</li> </ol>	<ol style="list-style-type: none"> <li>1. Reduce the force applied to the drill.</li> <li>2. Return to Clarke dealer for repair.</li> <li>3. Drip air tool lubricating oil into air inlet. Allow oil to soak moving parts before using.</li> </ol>
Tool runs slowly. Air flows weakly from exhaust.	<ol style="list-style-type: none"> <li>1. Motor parts jammed with gum/dirt.</li> <li>2. Regulator in closed position.</li> <li>3. General airflow blocked by dirt.</li> </ol>	<ol style="list-style-type: none"> <li>1. Examine inlet air filter for cleanliness.</li> <li>2. Adjust regulator to open position.</li> <li>3. Operate tool in short bursts.</li> </ol>
Tool will not run. Air flows freely from exhaust.	<ol style="list-style-type: none"> <li>1. Motor vanes stuck due to buildup of foreign material.</li> </ol>	<ol style="list-style-type: none"> <li>1. Disconnect air supply and rotate tool assembly manually.</li> <li>2. Try operating tool in short bursts.</li> <li>3. Tap motor housing gently with a rubber mallet.</li> <li>4. Drip a few drops of air tool lubricating oil into air inlet to soak moving parts.</li> </ol>
Tool will not shut off.	<ol style="list-style-type: none"> <li>1. O-rings damaged or ill-fitting in seat.</li> </ol>	<ol style="list-style-type: none"> <li>1. Return to Clarke dealer for repair.</li> </ol>

# PARTS DIAGRAM

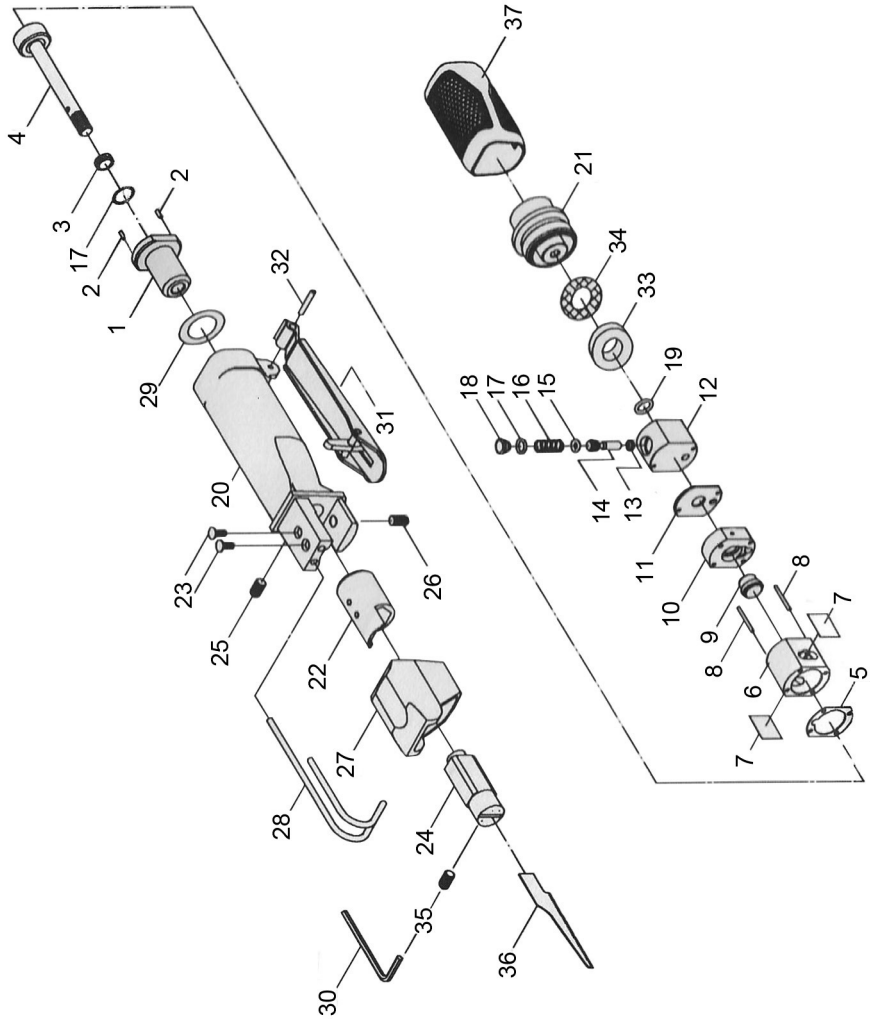

## COMPONENT PARTS

No	Description
1	Cylinder Head Assembly
2	Front Dowel Pin
3	Bumper
4	Piston
5	Gasket
6	Cylinder
7	Muffler
8	Rear Dowel Pin
9	Automatic valve
10	Valve Body
11	Valve Seat
12	Throttle Valve Case
13	O-Ring
14	Valve Stem
15	O-Ring
16	Spring
17	O-Ring
18	Throttle Valve Cap
19	O-Ring

No	Description
20	Handle Body
21	Throttle Arbor
22	Sliding Liner
23	Countersunk Screw
24	Blade Holder
25	Set Screw
26	Set Screw
27	Protective Cover
28	Work Guide
29	Front gasket
30	3mm Hex Wrench
31	Safety Lever Assembly
32	Roll Pin
33	Muffler
34	Air Filter
35	Set Screw
36	Saw Blade
37	Protective Grip

---

## SPECIFICATION

---

<b>Model Numbers</b>	<b>CAT167</b>
Part Number	3120181
Recommended Hose Size (ID)	10 mm (3/8")
Air Inlet Size	1/4" BSP Female
Max Operating Pressure	90 psi (6.2 bar)
Air Consumption (Average)	6 cfm (169 l/min)
Air Consumption (Max)	13 cfm (368 l/min)
Max Speed	10000 rpm @ 90psi
Sound Pressure Level (LpA dB)	89 dB(A)
Sound Power Level (LwA dB)	100 dB(A)
Vibration Levels	13.9 m/s <sup>2</sup>
Vibration Uncertainty K:	1.5
Weight	0.54 kg
Blade Length	75 mm
No of Teeth	18/24/32 tpi

Please note that the details and specifications contained herein are correct at the time of going to print. However CLARKE International reserve the right to change specifications at any time without prior notice.

# DECLARATIONS OF CONFORMITY



Fitzwilliam Hall, Fitzwilliam Place, Dublin 2

## DECLARATION OF CONFORMITY

This is an important document and should be retained.

We hereby declare that this product(s) complies with the following directive(s):  
2006/42/EC  
*Machinery Directive*

The following standards have been applied to the product(s):

EN / ISO 11148-12:2012

The technical documentation required to demonstrate that the product(s) meet(s) the requirement(s) of the aforementioned directive(s) has been compiled and is available for inspection by the relevant enforcement authorities.

The CE mark was first applied in: 2017

**Product Description:**

Air Sabre Saw

**Model number(s):**

CAT167

**Serial / batch Number:**

N/A

**Date of Issue:**

19/05/2022

**Signed:**

J.A. Clarke  
Director

CAT167 CE Clarke.DOC (05/1922)

Page 1 of 1



Hemmill Street, Epping, Essex CM16 4LG

## DECLARATION OF CONFORMITY

This is an important document and should be retained.

We hereby declare that this product(s) complies with the following statutory requirement(s):  
*Supply of Machinery (Safety) Regulations 2008*

The following standards have been applied to the product(s):

EN / ISO 11148-12:2012

The technical documentation required to demonstrate that the product(s) meet(s) the requirement(s) of the aforementioned legislation has been compiled and is available for inspection by the relevant enforcement authorities.

The UKCA mark was first applied in: 2022

**Product Description:**

Air Sabre Saw

**Model number(s):**

CAT167

**Serial / batch Number:**

N/A

**Date of Issue:**

19/05/2022

**Signed:**

J.A. Clarke  
Director

CAT167 UKCA, Clarke.DOC (05/1922)

Page 1 of 1

# A SELECTION FROM THE VAST RANGE OF

# Clarke®

## QUALITY PRODUCTS



### **AIR COMPRESSORS**

From DIY to industrial, Plus air tools, spray guns and accessories.

### **GENERATORS**

Prime duty or emergency standby for business, home and leisure.

### **POWER WASHERS**

Hot and cold, electric and engine driven - we have what you need

### **WELDERS**

Mig, Arc, Tig and Spot. From DIY to auto/industrial.

### **METALWORKING**

Drills, grinders and saws for DIY and professional use.

### **WOODWORKING**

Saws, sanders, lathes, mortisers and dust extraction.

### **HYDRAULICS**

Cranes, body repair kits, transmission jacks for all types of workshop use.

### **WATER PUMPS**

Submersible, electric and engine driven for DIY, agriculture and industry.

### **POWER TOOLS**

Angle grinders, cordless drill sets, saws and sanders.

### **STARTERS/CHARGERS**

All sizes for car and commercial use.

## **PARTS & SERVICE: 0208 988 7400**

### **Parts Enquiries**

[Parts@clarkeinternational.com](mailto:Parts@clarkeinternational.com)

### **Servicing & Technical Enquiries**

[Service@clarkeinternational.com](mailto:Service@clarkeinternational.com)

SALES: UK 01992 565333 or Export 00 44 (0)1992 565335

**Clarke** INTERNATIONAL Hemnall Street, Epping, Essex CM16 4LG  
[www.clarkeinternational.com](http://www.clarkeinternational.com)